

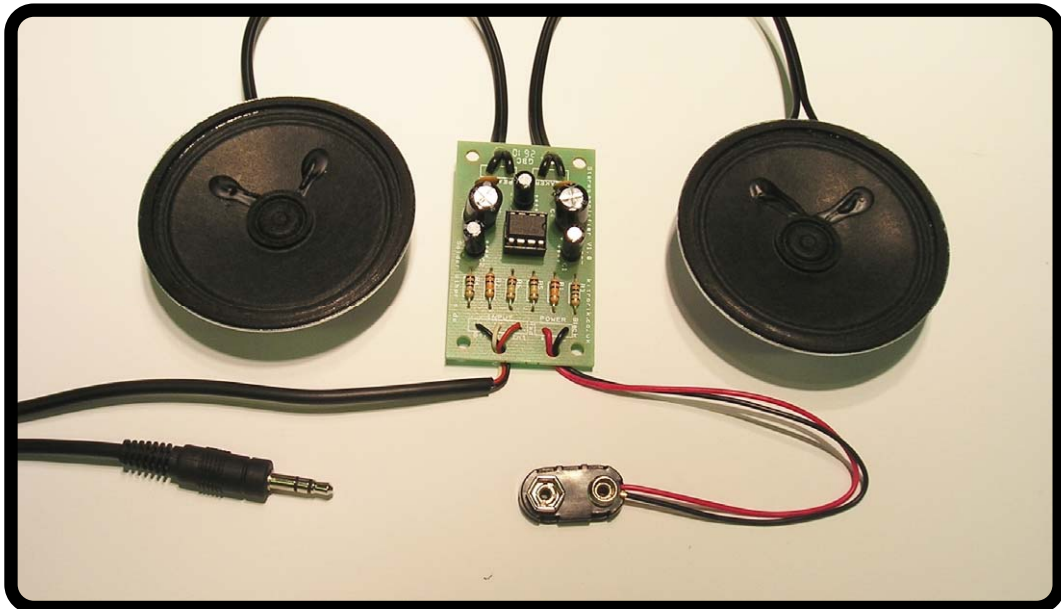

## MP3 stereo amplifier



## Build Instructions

Issue 1.0



## Build Instructions

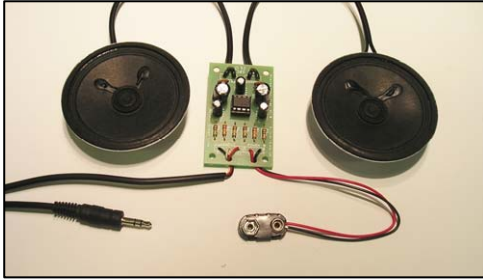

Before you put any components in the board or pick up the soldering iron, just take a look at the Printed Circuit Board (PCB). The components go in the side with the writing on and the solder goes on the side with the tracks and silver pads.

You will find it easiest to start with the small components and work up to the taller larger ones.

### Step 1

Start with the six resistors (shown right):

The text on the PCB shows where R1, R2 etc go. Make sure that you put the resistors in the right place.

R1 and R2 are 10K (brown, black, orange coloured bands)  
R3 and R4 is a 4.7Ω (yellow, purple, gold coloured bands)  
R5 and R6 are 100K a (brown, black, yellow coloured bands)

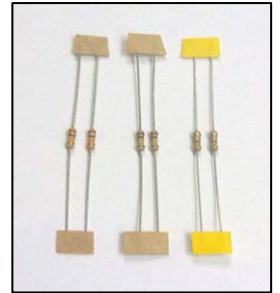

### Step 2

Solder the Integrated Circuit (IC) holder in to IC1. When putting this into the board, be sure to get it the right way around. The notch on the IC holder should line up with the notch on the lines marked on the PCB. Once this has been done insert the 8 pin IC into this socket making sure that the notch on the device matches the notch on the IC holder.

### Step 3

There are two ceramic disc capacitors (as shown right). These should be soldered into C6 and C7. It does not matter which way around they go.

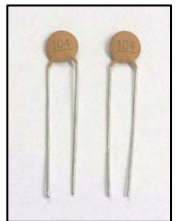

### Step 4

Now solder in the five electrolytic capacitors (an example is shown left). The capacitors have text printed on the side that indicates their value. The capacitors are placed as:  
C1 and C2 = 100μF. C3 = 10μF. C4 and C5 = 470μF.

Make sure the capacitors are the correct way around. The capacitors have a '-' sign marked on them which should match the same sign on the PCB

### Step 5

The kit is supplied with a meter of twin cable. This cable will be used to connect the two speakers. You will need to cut this to the required length for each speaker in your enclosure design.

Take each piece of wire that you have cut off and strip the ends of the wire. Connect one end of each to the two terminals on the speaker (shown right) and the other end of each to the terminals on the PCB marked SPEAKER1 and SPEAKER2 after feeding it through the strain relief hole. It does not matter which way around these connections go.





### Step 6

The PP3 battery clip (shown left) should be attached to the terminals labeled POWER. Connect the red wire to '+' and the black wire to '-' after feeding it through the strain relief hole.

### Step 7

The stereo jack lead (see picture right) should be connected to the 'INPUT' terminal. First feed the wires through the strain relief hole. The black wire should be connected to the terminal labeled 'BLK'. The other two can go to either of the two remaining inputs.

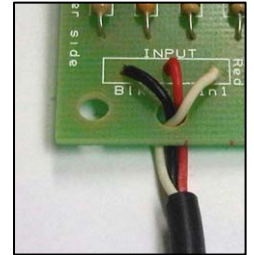

## Adding an on / off switch

If you wish to add a power switch, don't solder both ends of the battery clip directly into the board, instead:

- Solder one end of the battery clip to the PCB, either black to '-' or red to '+'.  
• Solder the other end of the battery clip to the on / off switch.  
• Using a piece of wire, solder the remaining terminal on the on / off switch to the remaining power connection on the PCB.

## Checking Your Amplifier PCB

Carefully check the following before you insert the batteries:

**Audio equipment may become damaged if connected to an incorrectly built amplifier.**

### Check the bottom of the board to ensure that:

- All holes (except the 4 large (3 mm) holes in the corners) are filled with the lead of a component.
- All these leads are soldered.
- Pins next to each other are not soldered together.

### Check the top of the board to ensure that:

- The four wires are connected to the right place.
- The '-' on the capacitors match the same marks on the PCB.
- The colour bands on R1 & R2 are brown, black, orange.
- The colour bands on R3 & R4 are yellow, purple, gold.
- C3 is a 10 $\mu$ F capacitor.
- The battery clip red and black wires match the red & black text on the PCB.
- The notch on the IC is next to C1 & C4.



## Fault finding flow chart

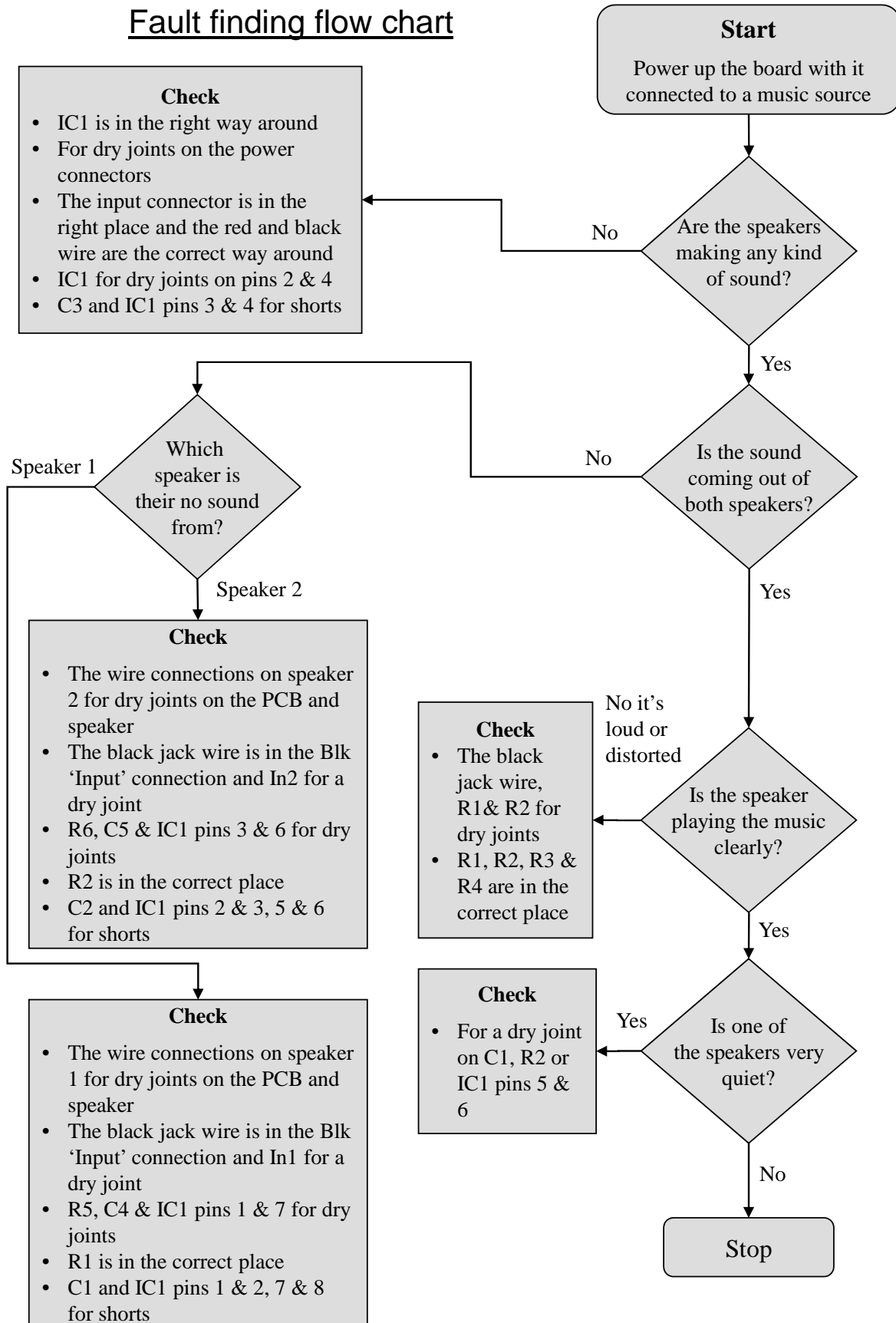



## How the Amplifier Works

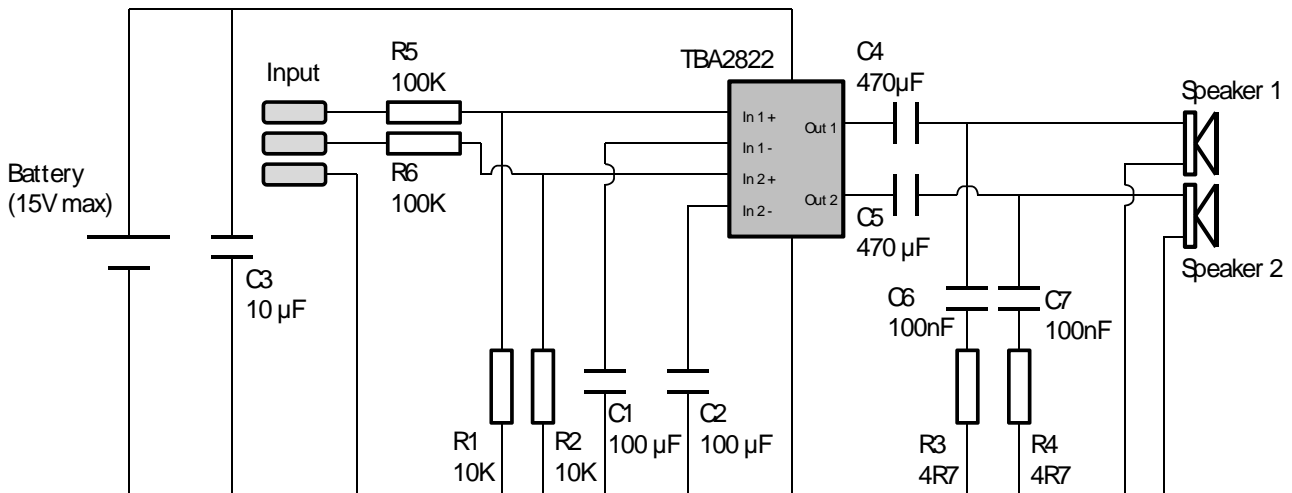

At the centre of the circuit is an audio amplifier Integrated Circuit or IC. Inside the IC are lots of transistors, which are connected together to allow the small input signal to be amplified into a more powerful output that can drive a speaker.

All amplifiers need to use feedback to ensure the amount of gain stays the same. This allows the output to be an exact copy of the input just bigger. The gain is the number of times bigger the output is compared to the input, so if an amplifier has a gain of 10 and there is 1 volt on the input there will be 10 volts on the output. An operational amplifier has two inputs, these are called the inverting (-) and non-inverting (+) inputs. The output of the operational amplifier is the voltage on the non-inverting input less the voltage on the inverting input multiplied by the amplifiers gain. In theory an operational amplifier has unlimited gain so if the non-inverting input is a fraction higher than the inverting input (there is more + than -) the output will go up to the supply voltage. Change the inputs around and the output will go to zero volts. In this format the operational amplifier is acting as a comparator, it compares the two inputs and changes the output accordingly.

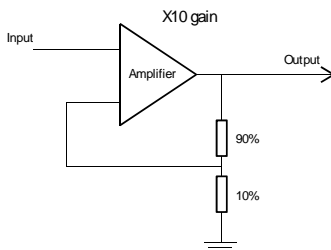

With an infinite gain the amplifier is no good to amplify audio, which is where the feedback comes in. By making one of the inputs a percentage of the output the gain can be fixed, which allows the output to be a copy of the input but bigger. Now when the two inputs are compared and the output is adjusted, instead of it going up or down until it reaches 0 volts or  $V+$ , it stops at the point when the two inputs match and the output is at the required voltage.

Looking at the circuit diagram for the audio amplifier it's not obvious where the feedback is, this is because it is inside the IC. The TB2822M chip has fixed the gain so the output is about 90 times bigger than the input. To make the gain useful in our application there is a potential divider on each channel that is fed into the IC (R1+R5 and R2+R6). Each of these reduces the input signal to only 10% of the original signal. This therefore reduces the overall gain of the amplifier to about 9 times the input to the circuit.

C3 is connected across the supply to make sure it remains stable. The other capacitors have a filtering role, either to cut out high frequency noise or get the best out of the speaker.