

SPECIFICATION

1. SCOPE

This specification is applied to the piezoelectric diaphragm.

2. SPECIFICATION

2.1 Resonant Frequency	:	4.0 ± 0.5	KHz
2.2 Resonant Resistance	:	300	• • max
2.3 Capacitance	:	25000	pF ± 30% at 100Hz
2.4 Input Voltage	:	30	Vp-p max
2.5 Operating Temperature	:	-20 ± 50	• •
2.6 Storage Temperature	:	-20 ± 70	• •

3. DIMENSION

as per figure

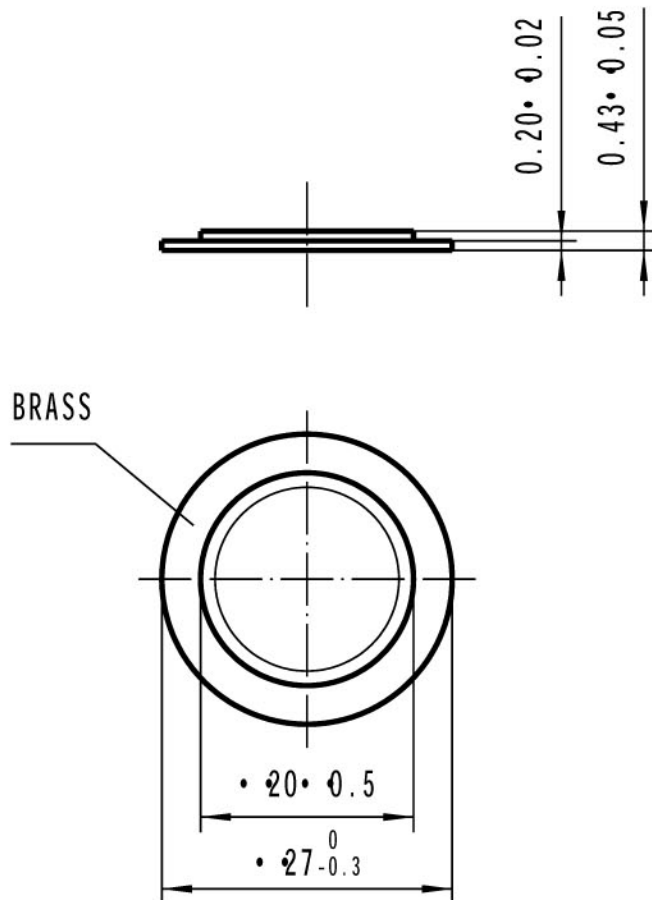

TOLERANCES UNLESS NOTED OTHERWISE .X •• .XX •• .XXX •• 90° FORMED +2•• ANGLES -1••		SIGN	DATE		CUSTOMER	
	PREP.		01.06.20		CUSTOMER NO.	
	ENG.				REV 1.0 SHEET	
	QA.				UNIT: mm SCALE	
	PROJ.					
CONTRACT NO.						
FIRST ANGLE PROJECTION				AGENCY APPROVAL		

